

# County of Santa Cruz

## DEPARTMENT OF PARKS, OPEN SPACE & CULTURAL SERVICES

979 17<sup>TH</sup> AVENUE, SANTA CRUZ, CA 95062

(831) 454-7901 FAX: (831) 454-7940 TDD: (831) 454-7978

JEFF GAFFNEY  
DIRECTOR

### ARTS COMMISSION – AGENDA

Monday, January 27, 2025  
4:30 p.m.  
Regular Meeting

Simpkins Family Swim Center Community Room  
979 17<sup>TH</sup> Avenue  
Santa Cruz, CA 95062

**I. CALL TO ORDER / ROLL CALL**

**II. AGENDA MODIFICATIONS OR APPROVAL**

**III. ORAL COMMUNICATIONS:** Any person may address the Commission during its Oral Communication period. Speakers must not exceed two (2) minutes in length, or the time limit established by the Chair, and individuals may speak only once during Oral Communications. All Oral Communication must be directed to an item listed on today's Consent Agenda, yet to be heard on Regular Agenda, or a topic not on the agenda that is within the jurisdiction of the Commission. Commission members will not take actions or respond immediately to any Oral communication presented regarding topics not on the agenda but may choose to follow up later, either individually or on a subsequent Commission Agenda. Oral communications will normally be received by the Commission for a period not to exceed thirty (30) minutes. If, at the end of this period, additional persons wish to address the Commission, the Oral Communication period may be continued to the last item on the agenda.

**IV. CONSENT AGENDA**

a. Approve meeting minutes from December 9, 2024 ..... Pages 2-4

**V. STAFF REPORTS**

**VI. REGULAR AGENDA**

**A. Information/Discussion Items**

1. Legacy Award – criteria
2. % for Arts in Private Development

**B. Action Items**

1. Selection Panel's Recommendation of Public Artist for the Hidden Beach public art project..... Pages 5-12
2. Chamber award - arts category – consider forming subcommittee
3. Appoint Commissioner to serve on the Juvenile Hall Public Art Selection Panel (replace Commissioner DeWorken, who resigned).
4. Appoint Commissioner to serve as Vice Chair of the commission through June 30, 2025 (replace Commissioner DeWorken, who resigned).

**VII. AGENDA / MEETING FOR: March 3, 2025 – 4:30 PM**

**VIII. ADJOURNMENT**

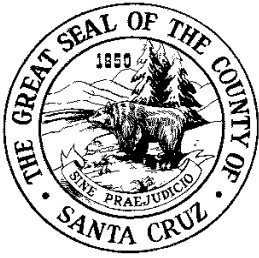

# County of Santa Cruz

## PARKS, OPEN SPACE & CULTURAL SERVICES

979 17<sup>TH</sup> AVENUE, SANTA CRUZ, CA 95062

(831) 454-7901 FAX: (831) 454-7940 TDD: (831) 454-7978

JEFF GAFFNEY  
DIRECTOR OF PARKS

### ARTS COMMISSION MINUTES December 9, 2024, 3:00 p.m. – 979 17<sup>th</sup> Ave., Santa Cruz

**DRAFT**

I. Called to order at 3:11 p.m. Present: Niven, Phillips, Stabile, Kroslowitz, Miranda, Leclerc  
Late (3:30PM): Singer Absent/Excused: Rogers Vacant seats:2  
Staff: Sarah Shea, Kathy DeWild

II. Approved Agenda with Modifications - Motion/Second: Miranda/Phillips  
Switch Items VI. B. 4 and 6

AYES: 6  
NOES: 0  
ABSTAIN: 0  
ABSENT: 2

III. Oral Communications – None

VI. Approved Consent Agenda - Motion/Second: Stabile/Kroslowitz

AYES: 6  
NOES: 0  
ABSTAIN: 0  
ABSENT: 2

V. Staff reports

Winter Wonderland will be held at the Swim Center on Saturday, Dec. 14 - it includes a holiday art/crafts market and Breakfast with Santa. A ribbon cutting for the new and improved playground at Floral Park will take place on Friday, Dec. 13. Pinto Lake will soon have a skate park feature at the front of the park, with funds provided by a donor. The Poetry & Music in the Park series concluded on Nov. 3 at Brommer Park. A call for nominations for both the 2025 Spotlight Award and the 2026 Artist of the Year Award will go out early next month. The Arts Commission recommendation of public artist for the Ben Lomond Transfer Station public art project goes before the Board of Supervisors in April, postponed from Dec 10. The Hidden Beach Public Art Project selection panel will meet on Dec. 10 to review proposals, with finalists being interviewed on Jan. 10. A Call for Juvenile Hall will go out early next year, followed in the spring by Calls for the Swim Center Slide Replacement and the Pace Trails. Paintings by Johanna McCormick and photographs by Kara Kapaldo will be on exhibition at the Swim Center/Live Oak Library Annex through January 2025. The 2025 Artist of the Year "Profile Performance" honoring Janet Johns will be held May 9 at the Crocker Theater, Cabrillo College.

VI. Regular Agenda

#### A. Information and Discussion Items

1. Arts Commission Attendance for 2023 and 2024 was provided for reference.
2. Youth in Arts subcommittee has nothing new to report.

## **B. Action Items Items**

1. Voted to approve and to recommend to the Board of Supervisors the selection panel's choice of public artist for Floral Park.

Motion/Second: Kroslowitz/Phillips

AYES: 7  
NOES: 0  
ABSTAIN: 0  
ABSENT: 1

- 2.

Voted to approve and to recommend to the Board of Supervisors the 2025 Public Art Plan.

Motion/Second: Stabile/Miranda

AYES: 7  
NOES: 0  
ABSTAIN: 0  
ABSENT: 1

3. Approved the 2025 Arts Commission meeting schedule.

Motion/Second: Kroslowitz/Singer

AYES: 7  
NOES: 0  
ABSTAIN: 0  
ABSENT: 1

4. Voted to approve and to recommend to the Board of Supervisors revisions to the Arts Commission by-laws.

Motion/Second: Stabile/Miranda

AYES: 7  
NOES: 0  
ABSTAIN: 0  
ABSENT: 1

5. Voted to approve and to recommend to the Board of Supervisors draft revisions to the Public Art & Design Guidelines.

Motion/Second: Kroslowitz/Leclerc

AYES: 7  
NOES: 0  
ABSTAIN: 0  
ABSENT: 1

6. Voted to approve the Arts Commission 2023/24 Biennial Report, and to send to the Board of Supervisors to accept and file.

Motion/Second: Kroslowitz/Leclerc

AYES: 7  
NOES: 0  
ABSTAIN: 0  
ABSENT: 1

7. Voted to table this item "Support Santa Cruz County Chamber of Commerce in establishing a new Arts Award Category & form subcommittee" until January meeting.

Motion/Second: Phillips/Kroslowitz

AYES: 7  
NOES: 0  
ABSTAIN: 0  
ABSENT: 1

8. Approved the new Legacy Award, with criteria and other details to be discussed at a future commission meeting.

Motion/Second: Kroslowitz/Miranda

AYES: 7

NOES: 0

ABSTAIN: 0

ABSENT: 1

**VII.** Next meeting date: January 27, 2025 – 4:30-6:00 PM. Agenda items may include:

- Consider Selection Panel's Recommendation of Public Artist for the Hidden Beach public art project
- Youth into the Arts subcommittee – appoint additional commissioners
- Appoint a commissioner to serve on the Juvenile Hall public art panel
- Public Art in Private Development
- Santa Cruz County Chamber of Commerce – Arts Award Category – form subcommittee
- Legacy Award - criteria

**VIII.** Adjournment – 5:47 PM

Motion/Second: Stabile/Kroslowitz

AYES: 7

NOES: 0

ABSTAIN: 0

ABSENT: 1



**SLOGAN**

**PUBLIC ART PROJECT**  
HIDDEN BEACH COUNTY PARK

**SHAUN LOGAN**

# SLOGAN

## VISUAL SUPPORT



LEFT / BACK WALL



RIGHT / BACK WALL

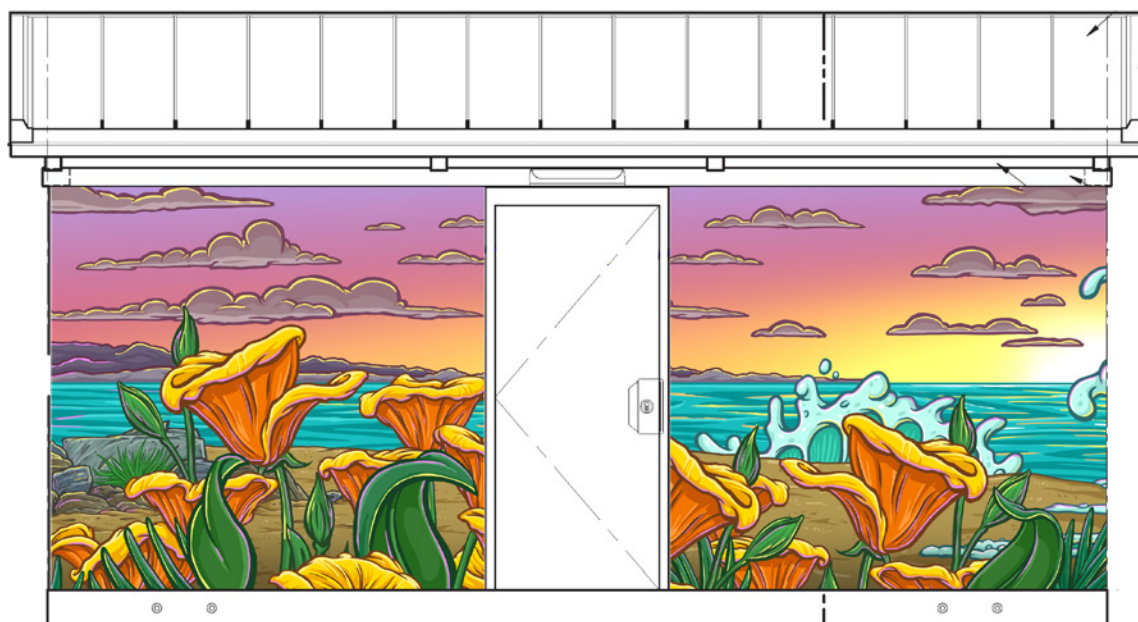

BACK WALL

# SLOGAN



LEFT / RIGHT WALL

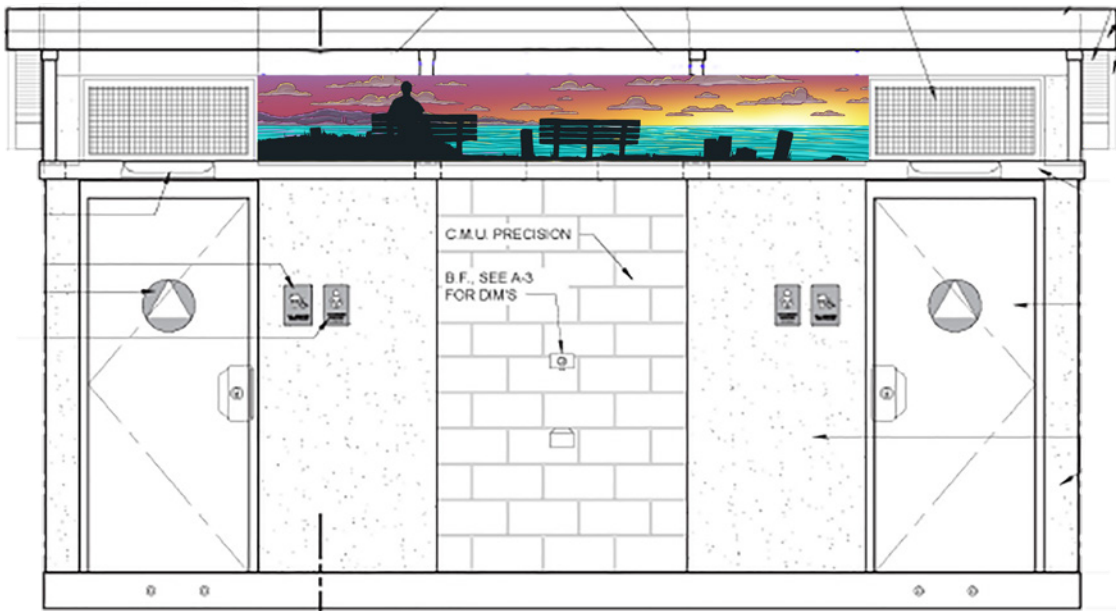

FRONT TOP WALL

# SLOGAN

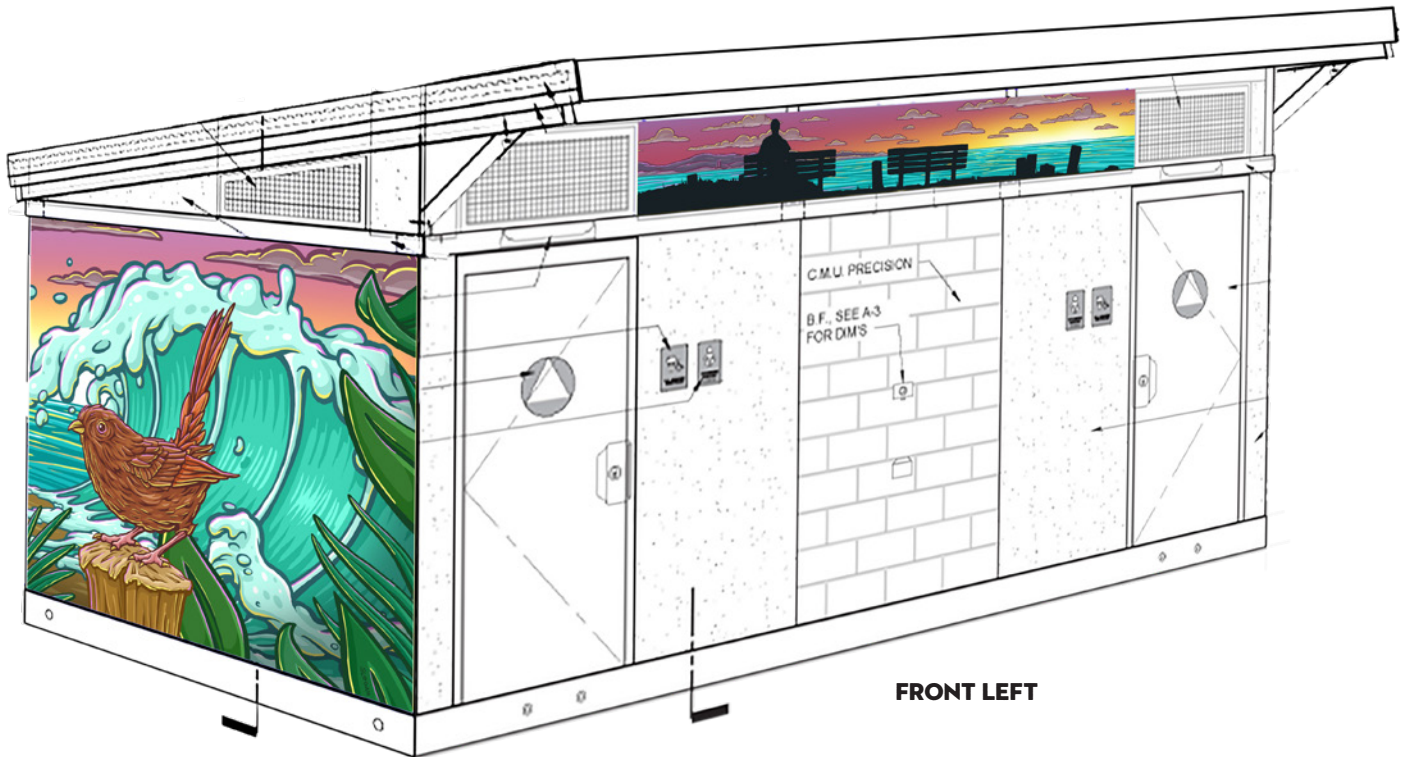
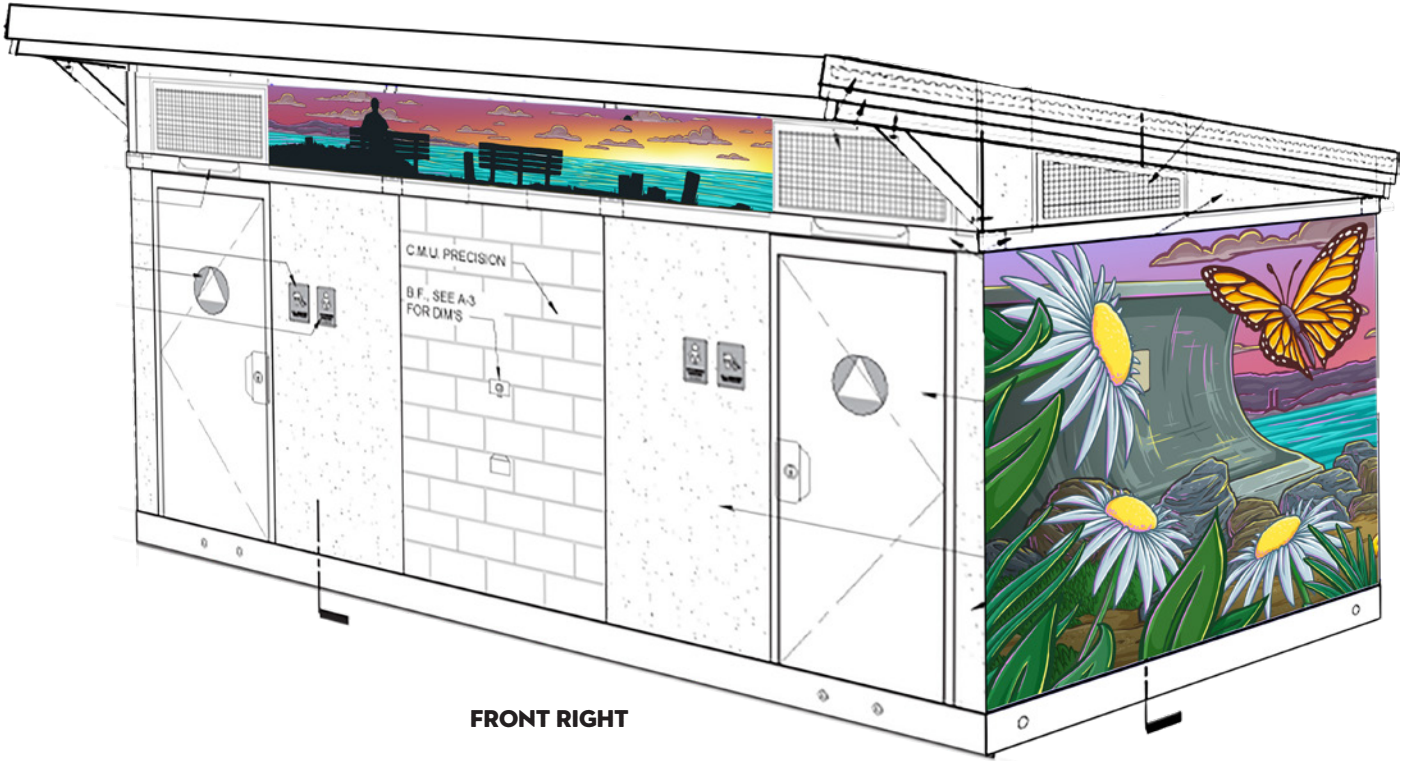



# SLOGAN

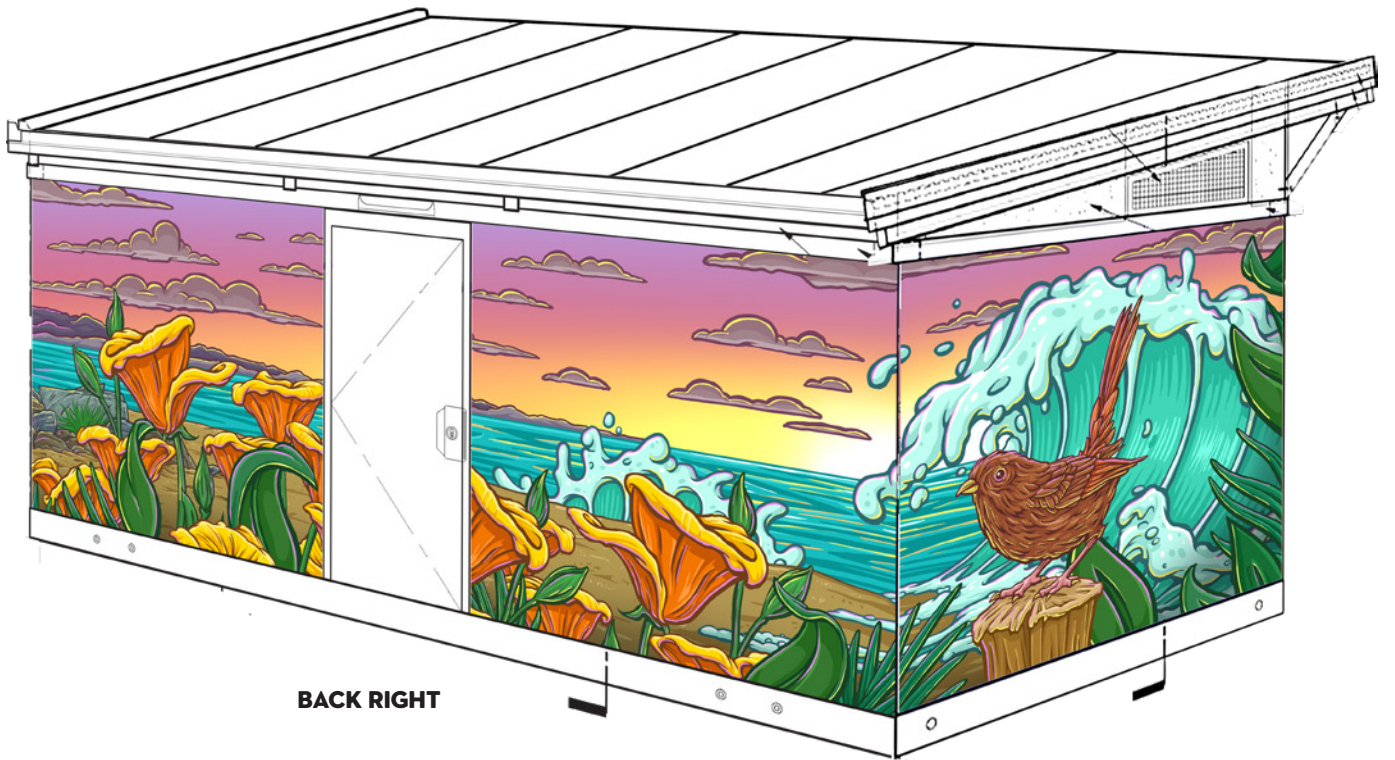

**BACK RIGHT**

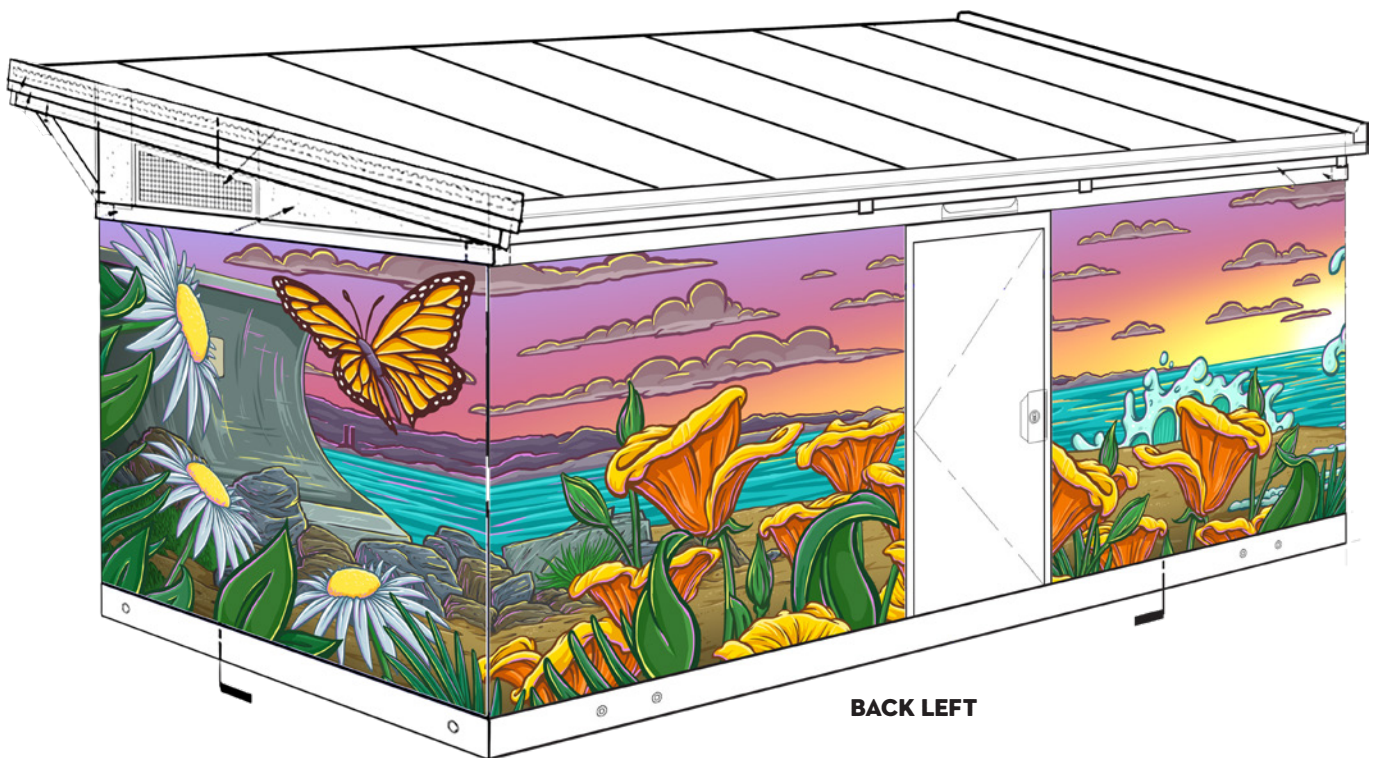

**BACK LEFT**

# SLOGAN



RESTROOMS SIGN



BEACH SIGN



# SLOGAN



February 28, 2024

**Parcels**

⋮ Parcels

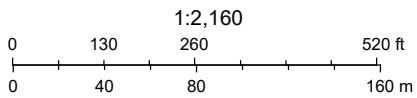

# SLOGAN

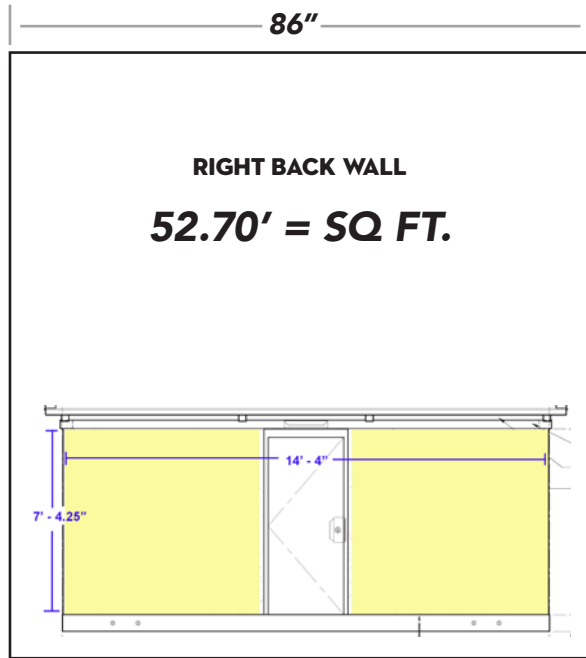
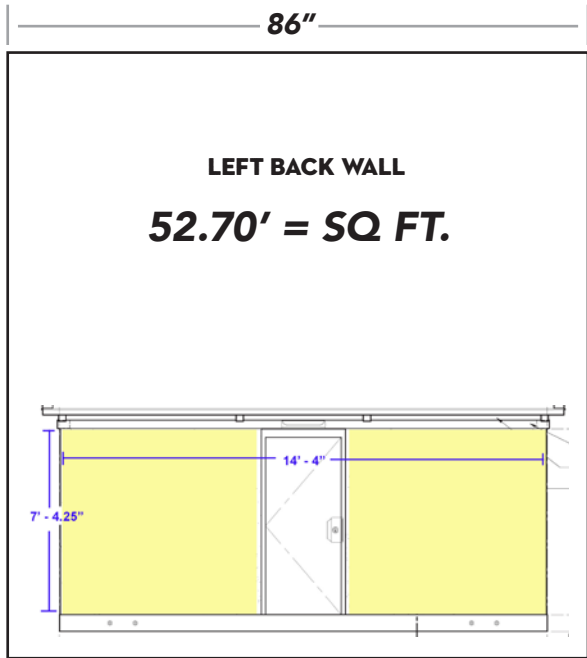

88.25"

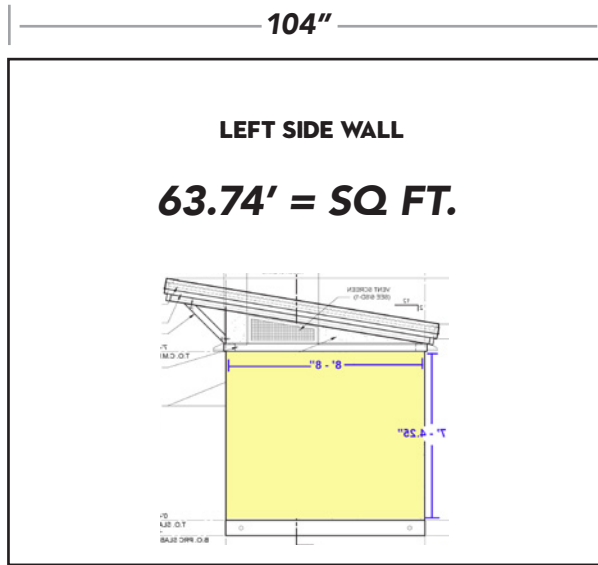
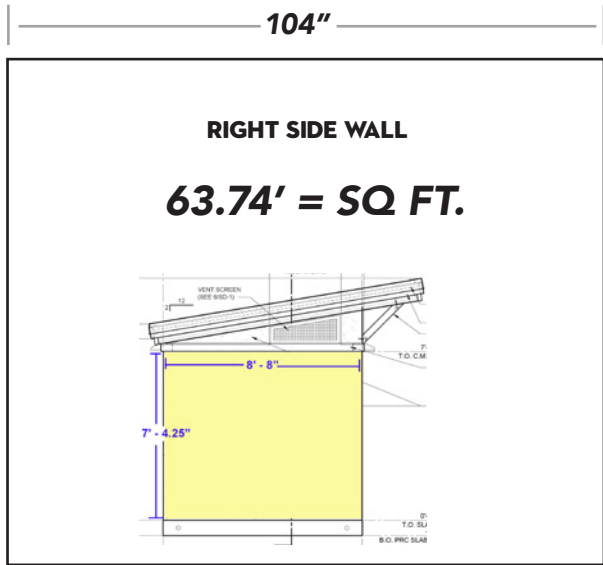

88.25"

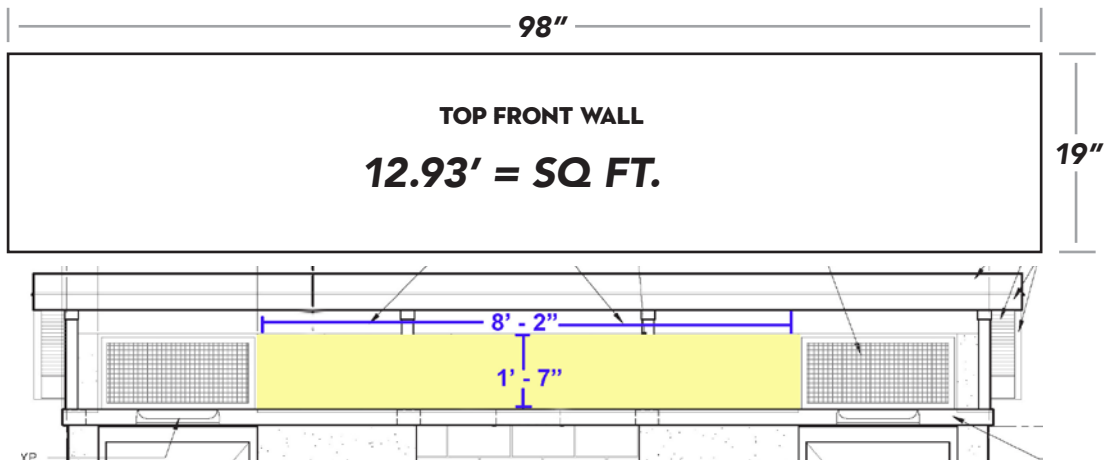

19"